

Powerex, Inc., 200 Hillis Street, Youngwood, Pennsylvania 15697-1800 (412) 925-7272  
 Powerex, Europe, S.A. 428 Avenue G. Durand, BP107, 72003 Le Mans, France (43) 41.14.14

### Phase Control SCR 300-350 Amperes 2400 Volts

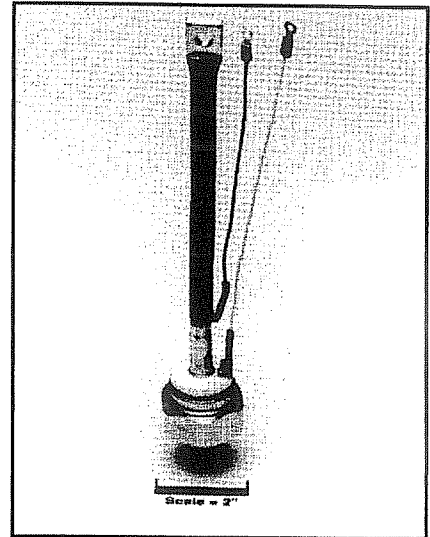
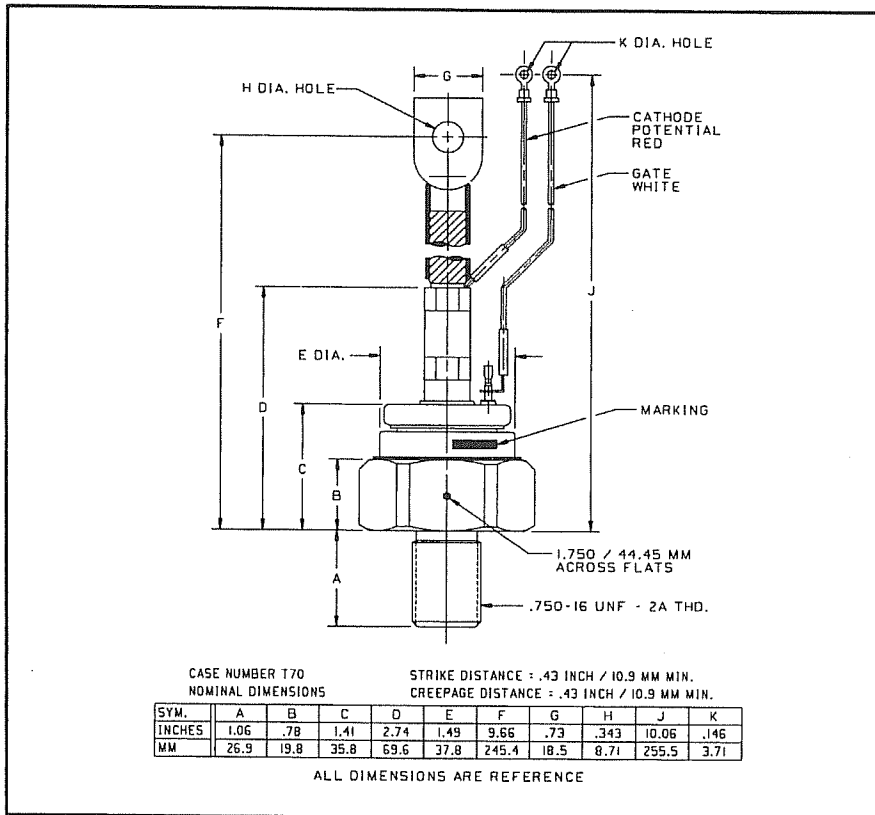

**T700 Phase Control SCR**  
 300-350 Amperes, 2400 Volts

T700 (Outline Drawing)

#### Ordering Information:

Select the complete eight digit part number you desire from the table, i.e. T7002435 is a 2400 Volt, 350 Ampere Phase Control SCR.

Type	Voltage		Current	
	$V_{DRM}$	Code	$I_{T(av)}$	Code
T700	200	02	300	30
	400	04	350	35
	600	06		
	800	08		
	1000	10		
	1200	12		
	1400	14		
	1600	16		
	1800	18		
	2000	20		
2200	22			
2400	24			

#### Description:

Powerex Silicon Controlled Rectifiers (SCR) are designed for phase control applications. These are all-diffused, compression bonded encapsulated (CBE) devices employing the field-proven amplifying (di/namic) gate.

#### Features:

- Low On-State Voltage
- High di/dt
- High dv/dt
- Hermetic Packaging
- Excellent Surge and  $I^2t$  Ratings

#### Applications:

- Power Supplies
- Battery Chargers
- Motor Control

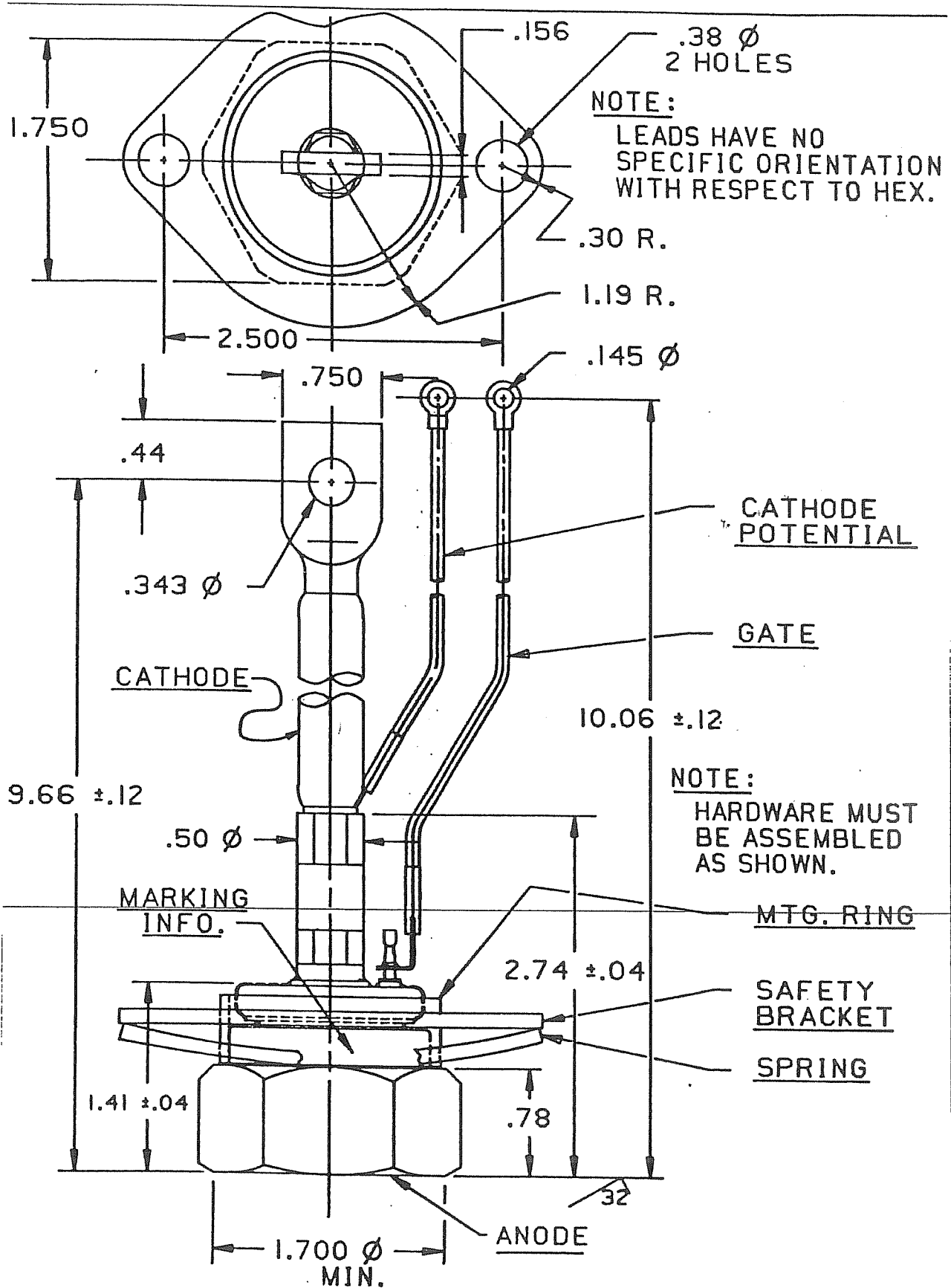

OUTLINE-T780



Powerex, Inc., 200 Hillis Street, Youngwood, Pennsylvania 15697-1800 (412) 925-7272  
 Powerex, Europe, S.A. 428 Avenue G. Durand, BP107, 72003 Le Mans, France (43) 41.14.14

T700  
 Phase Control SCR  
 300-350 Amperes, 2400 Volts

### Absolute Maximum Ratings

	Symbol	T700 _ _ 30	T700 _ _ 35	Units
RMS On-State Current	$I_{T(RMS)}$	470	550	Amperes
Average On-State Current	$I_{T(av)}$	300	350	Amperes
Peak One-Cycle Surge (Non Repetitive) On-State Current (60Hz)	$I_{TSM}$	8400	10,000	Amperes
Peak One-Cycle Surge (Non-Repetitive) On-State Current (50Hz)	$I_{TSM}$	7700	9100	Amperes
Critical Rate-of-Rise of On-State Current (Non-Repetitive)	$di/dt$	800	800	Amperes/ $\mu$ s
Critical Rate-of-Rise of On-State Current (Repetitive)	$di/dt$	150	150	Amperes/ $\mu$ s
$I^2t$ (for Fusing), 8.3 milliseconds	$I^2t$	295,000	416,000	A <sup>2</sup> sec
Peak Gate Power Dissipation	$P_{GM}$	16	16	Watts
Average Gate Power Dissipation	$P_{G(av)}$	3	3	Watts
Storage Temperature	$T_{STG}$	-40 to 150	-40 to 150	°C
Operating Temperature	$T_J$	-40 to 125	-40 to 125	°C
Mounting Torque		360	360	in.-lb.
Mounting Torque (Lubricated)		400	400	kg-cm

### Electrical and Thermal Characteristics

	Symbol	Test Conditions	T700 _ _ 30	T700 _ _ 35	Units
<b>Current—Conducting State Maximums</b>					
Peak On-State Voltage	$V_{TM}$	$T_J = 25^\circ\text{C}$ , $I_{TM} = 625\text{A}$	1.60	1.40	Volts
T700					
<b>Voltage—Blocking State Maximums</b>					
Forward Leakage, Peak	$I_{DRM}$	$T_J = 125^\circ\text{C}$ , $V_{DRM} = \text{rated}$	30		mA
Reverse Leakage, Peak	$I_{RRM}$	$T_J = 125^\circ\text{C}$ , $V_{RRM} = \text{rated}$	30		mA
<b>Switching</b>					
Typical Turn-Off Time	$t_q$	$I_T = 250\text{A}$ , $di_R/dt = 25\text{A}/\mu\text{sec}$ , reappplied $dv/dt = 20\text{V}/\mu\text{sec}$ linear to $0.8 V_{DRM}$ , $T_J = 125^\circ\text{C}$	150		$\mu\text{sec}$
Typical Turn-On Time	$t_{on}$	$I_T = 100\text{A}$ , $V_D = 100\text{V}$	7		$\mu\text{sec}$
Min. Critical $dv/dt$ exponential to $V_{DRM}$	$dv/dt$	$T_J = 125^\circ\text{C}$	300		$\text{V}/\mu\text{sec}$
<b>Thermal</b>					
Maximum Thermal Resistance Junction to Case	$R_{\theta JC}$		0.10		°C/Watt
Case to Sink, Lubricated	$R_{\theta CS}$		0.05		°C/Watt
<b>Gate—Maximum Parameters</b>					
Gate Current to Trigger	$I_{GT}$	$T_J = 25^\circ\text{C}$ , $V_D = 12\text{V}$	150		mA
Gate Voltage to Trigger	$V_{GT}$	$T_J = 25^\circ\text{C}$ , $V_D = 12\text{V}$	3		Volts
Non-Triggering Gate Voltage	$V_{GDM}$	$T_J = 125^\circ\text{C}$ , $V_{DRM} = \text{rated}$	0.15		Volts
Peak Forward Gate Current	$I_{GTM}$		4		Amperes
Peak Reverse Gate Voltage	$V_{GRM}$		5		Volts



Powerex, Inc., 200 Hillis Street, Youngwood, Pennsylvania 15697-1800 (412) 925-7272  
 Powerex, Europe, S.A. 428 Avenue G. Durand, BP107, 72003 Le Mans, France (43) 41.14.14

**T700**  
**Phase Control SCR**  
 300-350 Amperes, 2400 Volts

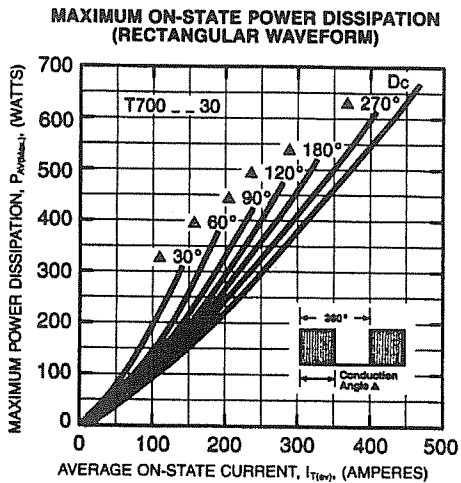
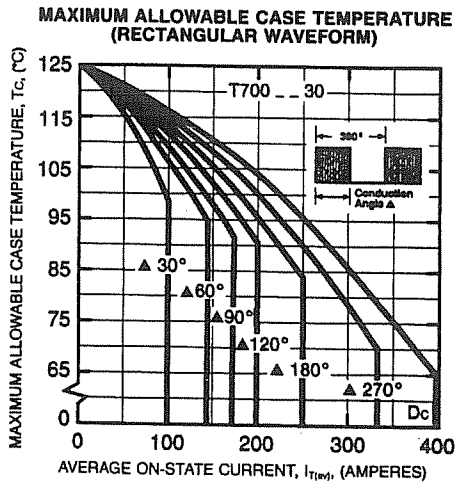
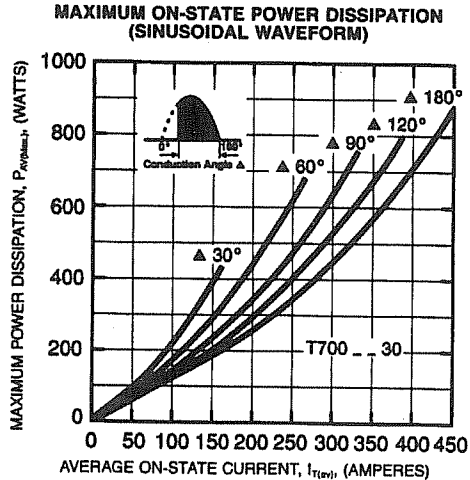
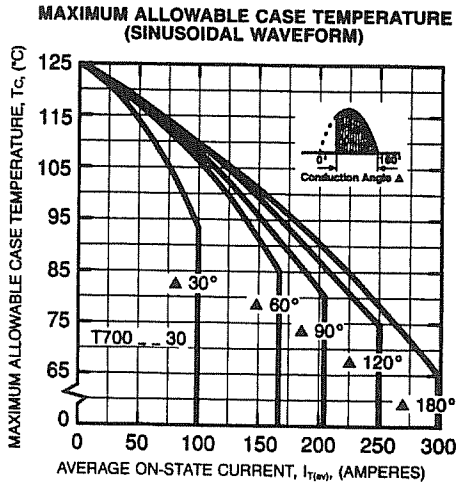
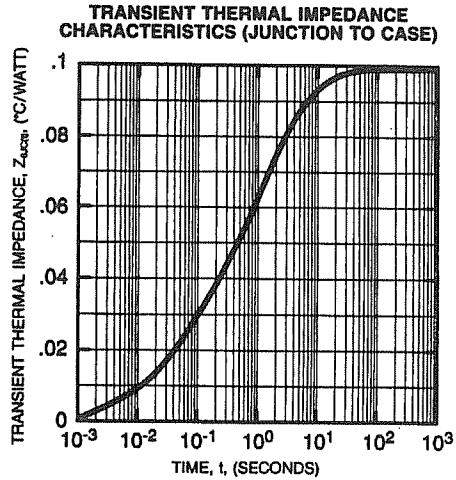
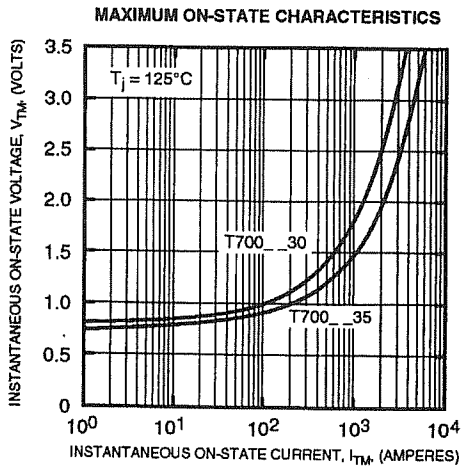

Powerex, Inc., 200 Hillis Street, Youngwood, Pennsylvania 15697-1800 (412) 925-7272  
 Powerex, Europe, S.A. 428 Avenue G. Durand, BP107, 72003 Le Mans, France (43) 41.14.14

**T700**  
**Phase Control SCR**  
 300-350 Amperes, 2400 Volts

